



LES PRESOIRS  
**COQUARD**  
PRESSES



The Quality  
Benchmark



# Egg

## Permanent Movement

Its design makes it the perfect tank for both fermentation and ageing. Its shape provides advantages in the winemaking of reds and whites, keeping the cap submerged. This characteristic results in intense macerations obtaining the maximum aroma and colour of the grape.

Due to its geometry, the wine can circulate freely, keeping the lees in suspension, thus preventing oxidation. Its ovoid shape provides a greater contact surface of the wine with its lees, reducing bâtonnage operations and saving time and work in the cellar.

**COQUARD PRESSES**

MANUFACTURERS OF FINE PRESSES IN CHAMPAGNE SINCE 1924

21 rue des Létis - 51430 Bezannes / [commercial@coquardpresses.com](mailto:commercial@coquardpresses.com) / Tél. +33 (0)3 26 36 58 57 / Fax +33 (0)3 26 49 95 45

### Experience, dedication, innovation, quality

Our line of concrete tanks is inspired by Roman terracotta amphorae, but redesigned and updated. These concrete tanks bear the soul of Sonoma Cast Stone products, allowing us to refocus years of experience towards European wine and beer producers.

Not only are our concrete tanks aesthetically attractive, but also their structure is different. We use a unique double layer system which provides them with greater strength and durability. That is why we offer a ten-year guarantee against cracks and leaks in all our concrete tanks.

Their temperature control system is fully integrated into the tank walls, without coming into contact with the wine, thus avoiding deposits of tartrates, colouring matter or yeasts. This system also facilitates cleaning and stirring operations, which represents a great improvement with respect to the coils and cooling plates.

We take care of every detail: in their manufacture, no chlorinated water or chemical additives that can affect the product are used. Also, the colour chosen is not applied superficially as paint, but as an aggregate in the mixture. In this way, we ensure homogeneity and uniformity in each product and avoid aesthetic damage due to deterioration. Harvest after harvest, your concrete tank will look the same as on the first day!

### Why concrete wine tanks?

#### A new alternative, by recovering a classic method

**Thermal inertia.** Due to its properties, concrete is not very sensitive to sudden temperature fluctuations. This translates into greater stability during the fermentation and ageing processes, which also leads to considerable energy savings.

**Micro oxygenation.** Thanks to its porosity, it is usually said that the concrete «breathes». This gives the wine better organoleptic characteristics. In ageing, concrete allows you to micro-oxygenate the wines without the aromatic impact of wood. Micro-oxygenation enhances the sensation in the mouth, getting more unctuous, more complex wines. In also, it stabilises and increases colour intensity, and it has been proven that it helps balance the fermentation of varieties with a tendency to reduction. Moreover, the natural qualities of concrete favour the clarification and stabilisation of the wine.

**Robust and durable.** The qualities of concrete ensure a long life for the tank. The 8 models of Sonoma by SAS can last a minimum of 20 years due to their double-

layer structure. In comparison, alternative products such as barrels have a limited life of 4-5 years.

**Terroir.** The neutrality of the concrete allows you to express the terroir, showing the virtues of the soil, the climate and the grape variety. It makes the grape the main feature by preserving the aromas of the place where it comes from, providing authenticity and typicity to the wines.

**Economic and time-saving.** Under the same conditions of humidity and temperature during ageing, a lower evaporation of wine is observed in concrete tanks, compared to barrels, registering only 0,5% evaporation, against the usual 5% of wood. That translates into fewer operations dedicated to the supervision and replacement of wine, generating obvious savings. Concrete tanks are easy to clean, contributing to a more efficient use of water.

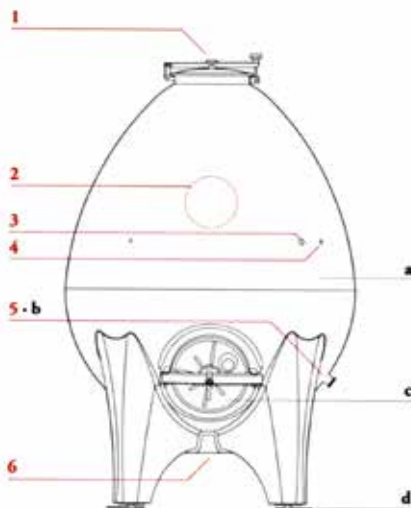

#### > Standard 18 HL

1. Top Manway
2. Winery logo
3. Thermowell
4. Sample port
5. Racking port
6. Drain port

#### > Options

- a. Embedded Glycol Heating
- b. Racking arm
- c. Pomace door
- d. Adjustable hold down legs

#### > Standard colors

Customised colours in the concrete topcoat.

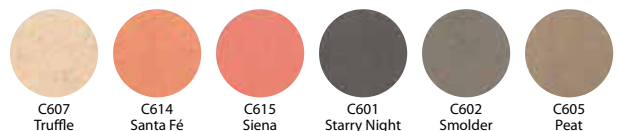

#### DATASHEET

Capacity	18 HL
Height	234 cm
Width	159 cm
Weight	2,2 t

#### Main advantages

- free movement of the lees preventing oxidation
- Greater contact with the lees and savings in *bâtonnage*
- Intense maceration

EXCLUSIVE DISTRIBUTOR IN CHAMPAGNE  
FOR ANY ENQUIRY, CONTACT US

21 rue des Létis - 51430 Bezannes

info@coquardpresses.com

Tél. +33 (0)3 26 36 58 57 / Fax +33 (0)3 26 49 95 45

[www.coquardpresses.com](http://www.coquardpresses.com)



## COQUARD PRESSES

MANUFACTURERS OF FINE PRESSES IN CHAMPAGNE SINCE 1924

Automatic and traditional hydraulic presses / Turn key installations / Automatic and volumetric regulation /  
Distribution and cooling system of the juices / Stainless steel and polyethylene settling tanks / Automatic grape feeder /  
Trailer and stainless steel screws for grape marc / Cat walk or platform / Lifting table / Maintenance